



Visit www.netico-group.com to download operation manual and other documentation. Type NTPM 110A in the search field.



When you see this symbol, refer to the user manual to get more information.

1

Unpacking

After unpacking, check the device and accessories for mechanical damages. **Do not use** the product if you notice any mechanical damage. Contact Netico or authorized representative for support.



2

Safety precautions

To ensure safety of personnel and property, and to avoid hazardous situations, please, read and follow all warnings, cautions and instructions provided with NTPM 110A product. Improper installation, mishandling, and misuse of NTPM 110A device can lead to equipment and property damage, personal injury or even death.

This equipment must be installed only by qualified professionals who has skills and knowledge related to electrical installations.

The manufacturer shall not be held responsible for failure to comply with the instructions in this manual.



DANGER



RISK OF ELECTROCUTION, BURNS OR EXPLOSION!

- Use appropriate personal protective equipment (PPE) and follow safe electrical work practices. In the USA and Canada, the equipment installation shall meet ANSI/NFPA 70, NEC, with CSA C22.1, CEC, Part I or with both as appropriate. In other countries, follow all local installation requirements and regulations.
- Prior to any work, isolate the voltage inputs and power supply inputs, and short-circuit the secondary winding of all current transformers.
- Always use appropriate voltage detection device to confirm the absence of voltage.
- Follow instructions in the Wiring section (5) of this publication.
- Do not exceed the equipment's ratings for maximum limits.
- Never short the secondary of a voltage transformer (VT)
- Never open circuit of a current transformer (CT).
- Always use grounded external CTs for current inputs.

Failure to take these precautions could cause serious injury or even death.



WARNING

RISK OF DAMAGING THE DEVICE!

- Before starting any maintenance, change in connections, repair, etc. the equipment must be disconnected from all power sources.
- When an operating fault or protection fault is suspected, the equipment must be taken out of service.
- Do not open the instrument under any circumstances when it is connected to a power source.
- Only qualified personnel familiar with the instrument and its associated electrical equipment must perform setup procedure.

3

Dimensions

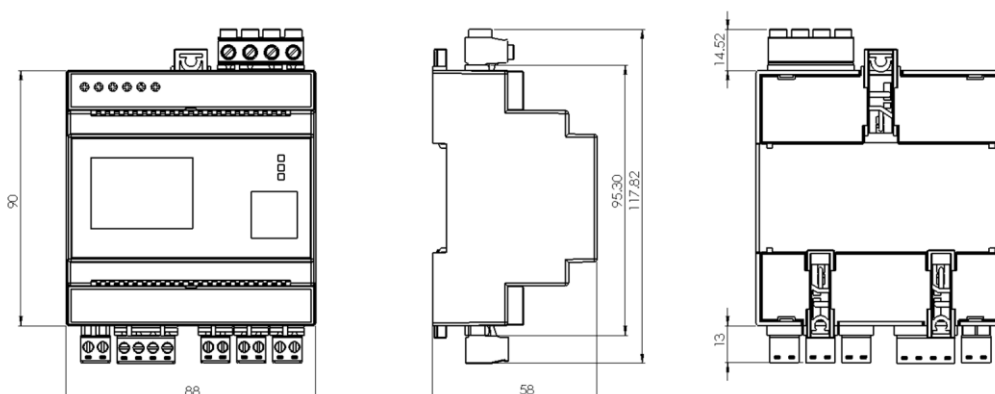

4

Mounting

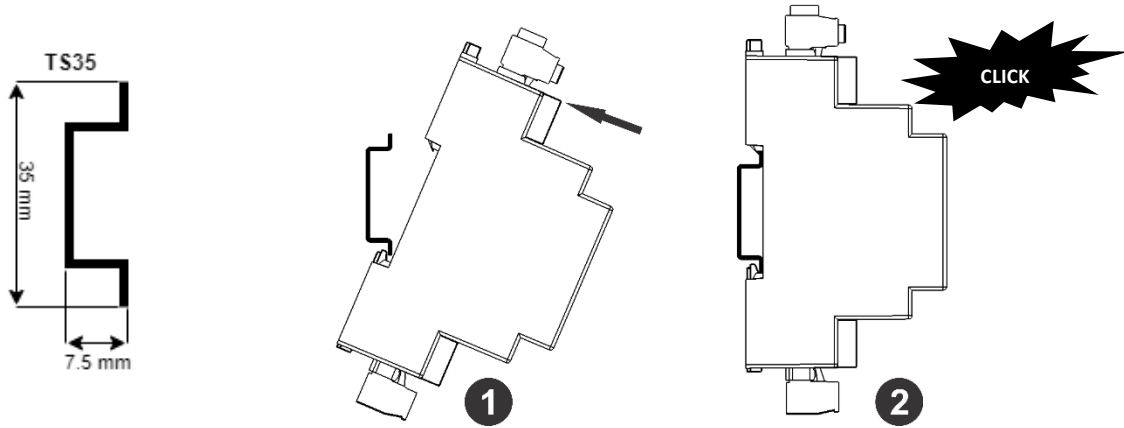

5

Wiring

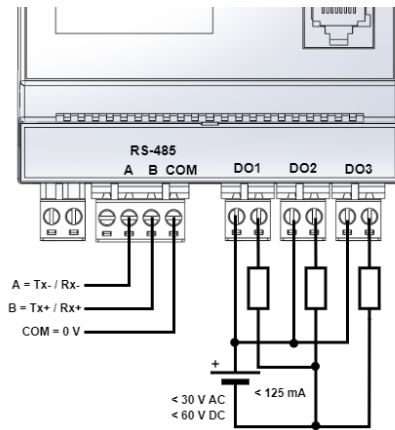
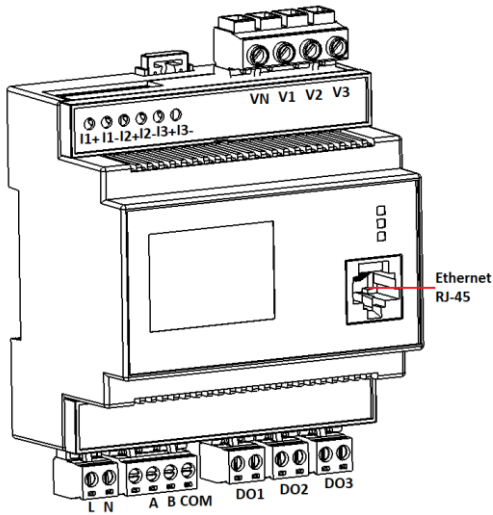

	Wire size	Stripping length	Drive form / screw thread	Torque	Limitations and remarks
V1, V2, V3, VN	0.5 – 2.5 mm ² (20 – 14 AWG)	8 mm	Slotted (L) / M3	0.5 – 0.6 Nm	Min 600V UL-recognized insulation system required. Cable rated for 90 °C or higher is required.
I1+, I1-, I2+, I2-, I3+, I3-	1 – 4 mm ² (17 – 12 AWG) 1 – 2.5 mm ² (17 – 14 AWG) with ferrule	6.5 mm	Phillips / M3	0.45-0.5 Nm	
L, N	0.75 – 3.3 mm ² (18 – 12 AWG)	7-8 mm	Slotted / M3	0.5 Nm	
A, B, COM [RS485]	0.25 – 3.3 mm ² (24 – 12 AWG)	7-8 mm	Slotted / M3	0.5 Nm	
DO1, DO2, DO3	0.25 – 3.3 mm ² (24 – 12 AWG)	7-8 mm	Slotted / M3	0.5 Nm	

	VT	CT	N.O. switch	
IEC				
ANSI				

CBs 500 mA circuit breakers, or fuses and disconnect switch

A Shorting block

Install the circuit breaker or fuse, listed for UL application on each mains connection.

Install an operator activated disconnecting device (circuit breakers or disconnect switch), near NTPM device, within easy reach of the operator and label it clearly to indicate the disconnection function.

The circuit breakers/fuses must be rated for the installation voltage and sized for the available fault current.

5

Wiring (continued)

For use with Listed Energy-Monitoring Current Transformers.

Listed surge protective with a suppression rating of max. 2500 Vpk is required.

These devices are not intended for installation within switchboards or panelboards.
These devices need to be installed within a dedicated electrical/fire enclosure.

Maximum voltage at voltage input terminals							
UL	347 VLN / 600 VLL	347 VLN / 600 VLL	600 VLL	600 VLL	600 VLL	347 VLN	347 VLN / 600 VLL
IEC	400 VLN / 690 VLL	347 VLN / 600 VLL	600 VLL	600 VLL	600 VLL	400 VLN	400 VLN / 690 VLL

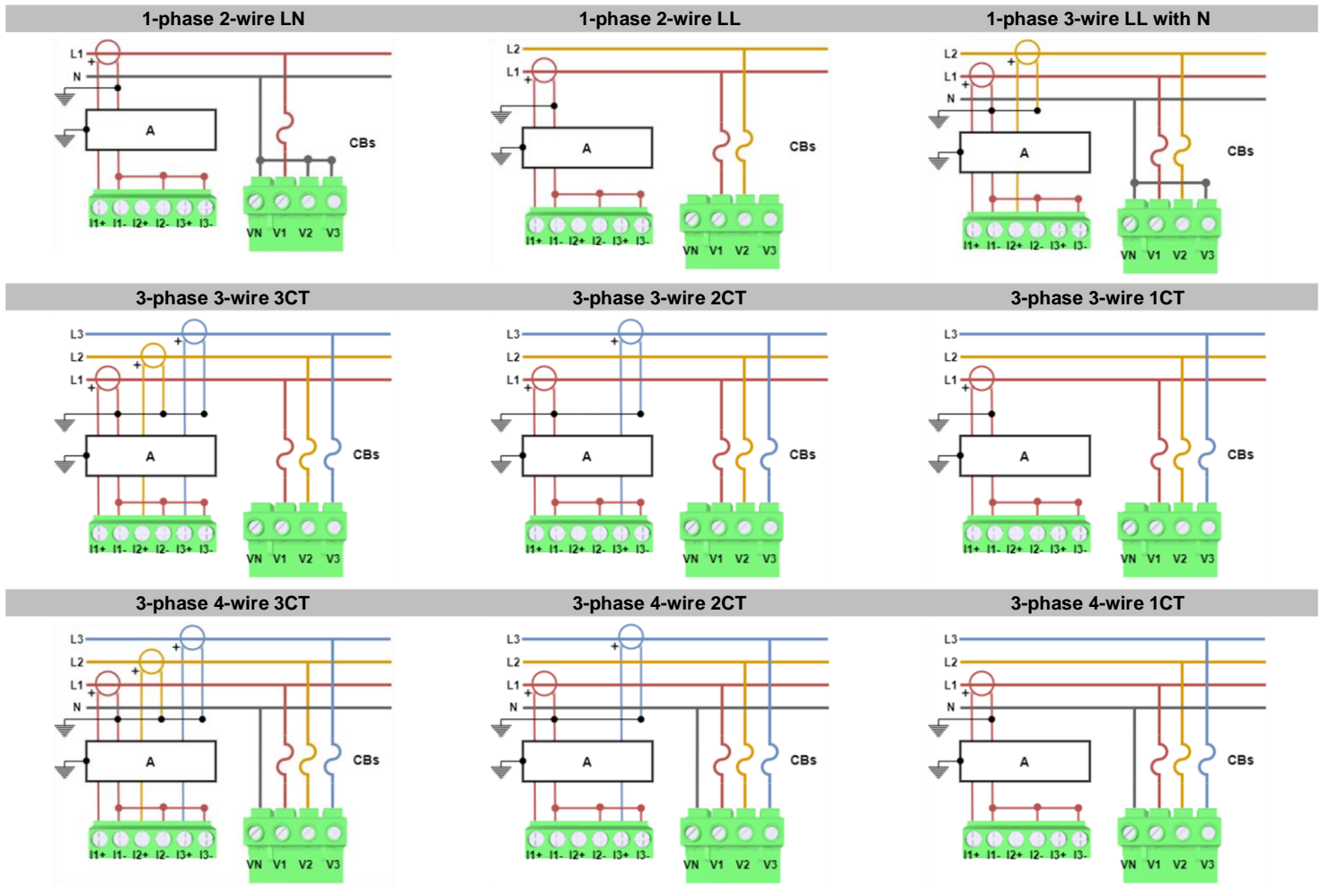

6

Power Supply

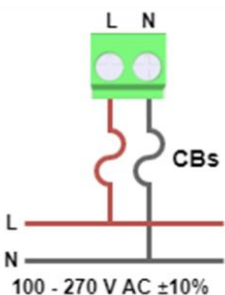

CBs 500mA circuit breakers / fuses

Connect phase line to L terminal and neutral line to N terminal.
Power supply terminals are rated for single-phase 100-270 VAC $\pm 10\%$, 50-60 Hz.

Always install circuit breaker / fuse on L. Use circuit breaker / fuse on N when connecting an ungrounded neutral to the power supply terminal.

The circuit breakers / fuses shall be UL listed and must be rated for the installation voltage and sized for the available fault current.

7

Connections and Controls

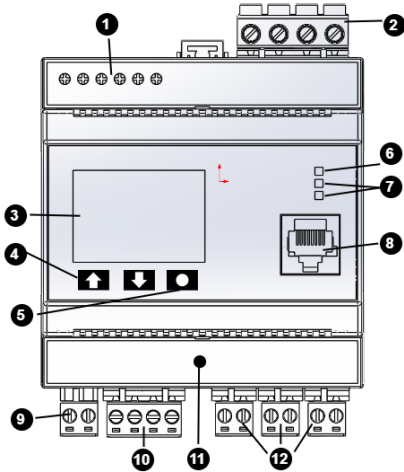

- | | |
|----------------------------------|--------------------|
| 1 Current inputs | 7 Ethernet LEDs |
| 2 Voltage inputs | 8 Ethernet |
| 3 Display (only 110A) | 9 Power supply |
| 4 Navigation buttons (only 110A) | 10 RS-485 |
| 5 Backlite button (only 110A) | 11 Restart button |
| 6 Power LED indicator | 12 Digital outputs |



8

Basic setup

First time configuration:

- Use the Ethernet cable to connect the PC to the device Ethernet port.
- Configure the PC Ethernet IP address and network mask:
 - PC IP address: 192.168.1.1
 - PC network mask: 255.255.255.0
- Test IP connectivity from the PC by using the PING tool.
- Open a web browser and enter 192.168.1.100 in the address bar.
- Log in as administrator (default Username = admin, Password = admin)
- Go to **TCP Configuration** page and modify parameters with the TCP settings obtained from you network administrator, then click **Submit**
- Go through the other configuration pages and edit device parameters to match your power system and electrical wiring.



9

Verification

Use navigation buttons on the front panel to go through the real-time data screens and verify that the device displays the correct values.

Or use a web browser to connect to the device and verify that its readings are correct.



10

Technical Data

Power supply

- Voltage: 100-270 V AC $\pm 10\%$
- Frequency: 50/60 Hz $\pm 10\%$
- Power consumption: max 2 W
- Overtoltage category II

Digital outputs

- Type: Form A solid state relay
- Maximum load voltage: 30 V AC / 60 V DC
- Maximum load current: 125 mA
- ON resistance: 8 Ω
- Isolation: 2500 V RMS for 1 minute

Voltage inputs

- Measured voltage: up to 400 V L-N / 690 V L-L (Wye) or 600 V L-L (Delta)
- Frequency: 50/60 Hz $\pm 10\%$
- Measurement category: CAT III 600 V
- Impedance: 5 M Ω
- Overload: 460 V L-N or 793 V L-L

Environment

- Operating temperature: -25 °C to 70 °C
- Relative humidity: 5% to 95% non-condensing
- Altitude: <2000 m
- Pollution degree 2

Current inputs

- Rated input current: 5 A
- Supported external CT with ratio up to 1:1000
- Maximum CT primary: 5000 A
- Measured current: up to 5000 mA
- Withstand: 6 A continuous, 20 A 10 sec, 50 A 1 sec



Netico GmbH
 Kummruetistrasse 103
 8810 Horgen
 Switzerland
 +381 43 810 45 21

www.netico-group.com